

High Speed Moving Mirror Goniophotometer Models # 6220, 6240 and 6440

Thirty years of continuous design refinements, software development and practical day-to-day usage enable Lighting Sciences Inc. to offer the High Speed Moving Mirror Goniophotometer as the standard of the lighting industry.

With truly unequalled speed, accuracy and functionality, LSI's photometric equipment is the most sophisticated available. Our clients know this is true, such that ***every major American lamp manufacturer has acquired Lighting Sciences' goniophotometers.***

LSI's High Speed Moving Mirror Goniophotometer delivers fast operation with accurate results no matter what type of lamp or luminaire test may be required. State-of-the-art computer hardware, coupled with sophisticated data collection and analysis software, provide a fully-automated test system. The equipment meets all applicable CIE and IESNA requirements.

The performance of the High Speed Moving Mirror Goniophotometer is dramatically fast. Thanks to the unique electronic characteristics and computerized controls of the system, data collection can be accomplished in a fraction of the time needed by most conventional goniophotometers. (Typically 3 minutes for indoor luminaires, 11 minutes for outdoor luminaires.)



The mirror runs at speeds up to 6 rpm, and readings can be collected at the rate of 10,000 or 12,000 per second. This allows integration over a 50 to 60 Hz (user selectable) waveform to overcome any AC ripple. It also ensures proper capturing of even the narrowest intensity peaks.

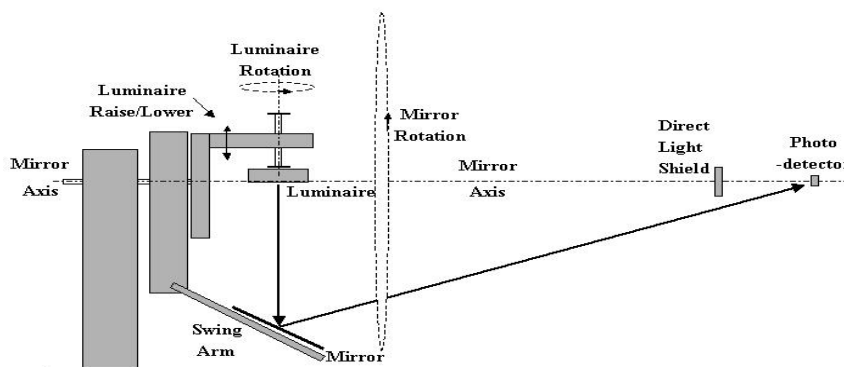

GONIOPHOTOMETER COMPONENTS

The High Speed Moving Mirror Goniophotometer consists of four basic components:

Mirror Swing-Arm and Support Structure

This component holds the test luminaire or lamp during testing and includes the support tower, mirror, swing-arm and luminaire mounting fixtures. The structure can be manufactured in several sizes, depending on the maximum size of item to be tested.

Photodetector Tower

A specially shielded unit houses the high-sensitivity photodetector used to obtain the photometric data. A rotating aperture mask that is sequenced with the mirror removes stray light. The photodetector is connected to a specially designed "Signal Maximizer" amplifier circuit, which automatically adjusts the system sensitivity or gain settings to ensure the highest possible accuracy throughout the test. A three-amplifier system is provided for exceptional dynamic range. The data are relayed to the computer interface through three 16-bit analog-to-digital converters.

Goniophotometer Integrated Console

This unit contains all of the system's electric and electronic equipment including main power switches, test lamp voltage adjustment, motor controllers and computer interfaces.

Computer Station

This includes a Windows XP or Vista-based computer and the photometric software to control the operation and data collection functions of the High Speed Moving Mirror Goniophotometer during testing. Additional software produces all forms of required reports and graphs (e.g. IES, CIE formats) and custom software packages.

Benefits Summary

- High-quality construction delivers years of trouble-free performance
- Precision digital drives provide unrivaled accuracy
- "Signal Maximizer" circuitry with three amplifiers enhances system sensitivity, dynamic range and accuracy
- 16-bit analog-to-digital converters
- Computer system avoids error-prone operator inputs
- Luminaire mounting system lowers to average chest height. Avoids hazardous "step-ladder" operations
- Attention to detail in design and appearance
- Automatic dark current compensation reduces errors, boosts accuracy
- Rotating aperture mask in front of photodetector allows only light from the mirror to enter. Room reflections are almost entirely eliminated
- Unmatched software selection for any test situation with the convenience of using the test data with nearly any design and analysis software
- Luminaire hard-wire power connections eliminate wear and electrical resistance errors inherent with slip-ring systems
- High-speed data collection - needs only a fraction of the time required by competitive systems. Mirror speed up to 6 rpm.
- Backed by the foremost producer of mirror goniophotometer systems in North America

COMPONENT FEATURES

Mirror Swing-Arm and Support Structure

The main support tower, swing-arm and mounting assembly are all engineered and manufactured to produce the most stable test platform available. Precision assembly ensures that the mirror swing-arm and counterweight are perfectly balanced to provide for continuously accurate alignment throughout all rotational positions.

To avoid the common problem of "mirror sag" associated with similar devices, the High Speed Moving Mirror Goniophotometer's mirror is bonded to its rigid steel backing. This is then bolted to the steel framework of the swing-arm, which guarantees a perfectly flat mirror surface, even at its uppermost zenith position.

Raising and lowering of the entire lamp/luminaire mounting assembly is motorized. It may be lowered to about 1.5m. (5 feet) above ground level so that the test technician can easily attach and connect the test lamp or luminaire. It then rises to the proper test height which is indicated by a wall-mounted laser that is aimed at the goniophotometer center. This design eliminates the need for inconvenient mounting platforms or ladders, which can be a dangerous liability, particularly when testing large or heavy luminaires.

The mounting assembly easily converts to hold downlight or uplight luminaires. (Illustrated in Figures A and B). In both instances the luminaire is positioned at the goniophotometer's centerline axis. Because the width of the luminaire attachment mechanism is only about 0.2m (8 ins.), light loss due to shadowing is kept to an absolute minimum.

Precision digital motors are coupled to the mirror shaft and the luminaire rotation shaft, and are constantly monitored by the system's computer, ensuring that both the mirror instantaneous position and the luminaire angle are precise throughout the test sequence. Resolution of each motor of the High Speed Moving Mirror Goniophotometer is an extremely fine 0.01 degrees.

Photodetector Tower

The photodetector is a high-sensitivity silicon cell with spectral sensitivity correction filtering. It offers high-speed response, excellent linearity and low drift, and is housed in a shielded box to exclude stray light and to prevent light from being received directly from the luminaire itself.

Within the photodetector housing is a digitally-controlled rotating aperture, which is synchronized electronically with the mirror rotation. This serves to block stray light from room surfaces, by allowing the photodetector to "see" only the mirror.

The photodetector is interfaced to the system computer using Lighting Sciences' exclusive Signal Maximizer™ electronic circuitry. This consists of a triple amplifier system.

Firstly, the primary amplifier sensitivity is set by the software to the highest gain setting that will not cause saturation or over-ranging. This is performed during a preliminary mirror scan. If higher light intensity is encountered during the test, auto-ranging occurs to reset the gain to the optimum level.

Secondly, two further amplifiers set with different sensitivities also constantly deliver readings; they record the lower light intensities encountered during the mirror scans. All three amplifiers are read simultaneously. This Signal Maximizer three-channel system ensures that there is a separate amplifier channel available for optimum readings

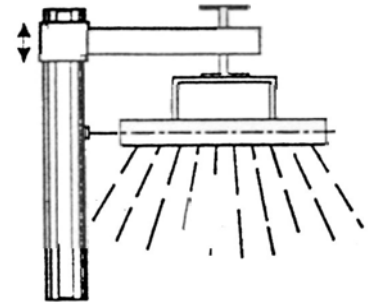

Figure A: Downlight Conversion

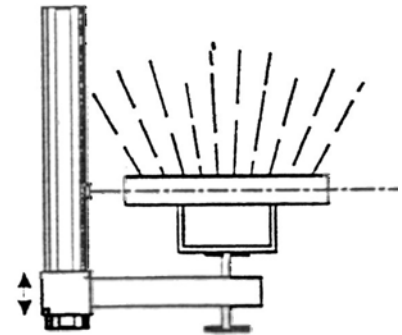

Figure B: Uplight Conversion

of high, medium and low light intensities at every instant during the mirror scans. This dramatically increases the goniophotometer dynamic range as compared to conventional systems.

The Signal Maximizer circuitry also automatically compensates for "dark current" – a signal generated by the electronics even when there is no light on the photodetector. This signal varies from one gain setting to the next, and if not properly accounted for, can create test result errors. Dark current values are automatically measured and applied to each gain stage throughout the test sequence without the need for operator input.

Amplifiers and electronics are located immediately adjacent to the photodetector, minimizing noise and maximizing signal stability. Interfacing between the photodetector amplifier and the computer is through use of three 16 bit analog-to-digital (A-to-D) converters, one for each channel.

Goniophotometer Console

This component contains all of the system's electrical and electronic controls. Main power switches and a test lamp voltage adjustment are included in the goniophotometer console.

A hand-held control box is also attached to the unit on an 8m. cord so the test operator can walk around the lab and manually position the luminaire during test set-up.

A remote Yokogawa power analyzer meter is installed which incorporates a large digital display of volts, amps and watts. The meter measures the exact lamp characteristics by use of remote sensing leads to the test luminaire.

An additional benefit of this system is that the power measurements on the ballast secondary of a high intensity discharge lamp are also facilitated. Readings are transmitted to the computer and displayed so that all electrical monitoring can be done from the computer station. Automated voltage or power adjustment controlled throughout the test by the computer is also available as an option.

Computer Station and Software

The functional heart of the High Speed Moving Mirror Goniophotometer is the computer hardware and software which control the system's entire operation. Virtually all functions of the system are computer automated including the mirror and lamp/luminaire rotation, selection of data points and the recording of data. Although the goniophotometer's operation is computer-controlled, manual over-rides additionally allow for unusual testing situations.

The computer system provided with the High Speed Moving Mirror Goniophotometer consists of MS Windows-based equipment totally configured and integrated to provide full system operation, data collection, processing, and report output.

Control Software

Comprehensive software developed by Lighting Sciences' test engineers and programmers controls the operation of the High Speed Moving Mirror Goniophotometer and gathers the appropriate test data for the particular type of luminaire being tested. Standard test formats are provided for indoor luminaires, area and roadway luminaires, floodlights, spotlights and bare lamps, and may be selected by the test operator from easy-to-use menus. The software includes the following features:

- Windows XP or Vista operating system
- Manual or automatic operation

LSI has installed
Moving Mirror
Goniophotometers
for clients such as:

Philips Lighting
Osram Sylvania
General Electric
Toshiba
China Electric Co.
Lightolier/Genlyte
Lithonia Lighting
Thomas Industries
Iwasaki Electric
Government of Egypt
Mitsubishi Electric
Genlyte

...and many more major
lamp manufacturers
and governments worldwide

- Automated control of mirror and luminaire rotation
- Automated data collection
- Display of intensity graph after first scan
- Selectable vertical angular increments
- Selectable luminaire rotation increments
- Pre-stored standard test data formats
- Customized test data formats set up by operator
- Automatic storage of test data

Data Processing Software

Data output files are produced which are compatible with Lighting Sciences' Photometric Suite™. (A brochure is available). This provides a wide range of test data processing software, which has been developed to produce attractive and easy-to-understand reports and graphical presentations. These data files may be processed on the photometer's computer or another compatible system for processing, including a network computer. The data processing software is equipped with a simple-to-use Windows interface that generates complete reports, including building of test report headings, application of calibration factors and insertion of a luminaire sketch.

With the custom software package, data can be exported to external spreadsheet software.

Plotting Programs

Software is also available to provide graphical output. Example plot packages that are provided include:

- Polar intensity (candlepower)
- Axially symmetric, bisymmetric and quadrilaterally symmetric distributions.
- Roadway plane and cone intensities.
- CIE C-0 and C-90 graphs
- Isofootcandle/Isolux
- IESNA and CIE roadway classification
- "Onion" isocandela
- Floodlight intensity (rectilinear)
- Floodlight isocandela (Type B/Beta)

CIE and IES Formats

LSI software supports both IES and CIE testing formats and reports. Floodlight reports are generated in Type B output (CIE B-Beta) while all others are in IESNA normal polar format or CIE type C-Gamma. American or International terminology is selectable (e.g., Candlepower or Intensity, Efficiency or Light Output Ratio, etc.). Reports can be based upon absolute or relative lamp lumens, or 1000 lumens.

Output Data Files

Provision is also made within the software for the generation of data files in accordance with various industry-standard file formats (IES, CIBSE, EULUM or CIE). This flexibility ensures that the test data produced by the High Speed Moving Mirror Goniophotometer are compatible with virtually all lighting software packages throughout the world.

Luminaire Size

Three different goniophotometer models are available depending upon the maximum size of luminaire to be tested:

Model	Maximum Luminaire Size
#6220	0.6 x 0.6m (2x2ft)
#6240	0.6 x 1.2m (2x4ft)
#6440	1.2 x 1.2m (4x4ft)

Custom-designed equipment to handle different luminaire sizes and to fit customer's specific room sizes is also available. Please request information.

Test Distance

The test distance is as specified by the customer. LSI can provide recommendations and room layout plans. The tilt angle of the mirror is set at installation to accommodate the required test distance.

INCLUDED ITEMS

Hardware:

- A main tower supporting the main horizontal shaft enclosed on all sides with black metal sheathing.
- A precision rotating mirror system incorporating 360 degrees rotation of the mirror around the test luminaire. Mirror is flat and mounted on a steel framework. System is provided with balancing counterweight. (180 degrees clockwise/counter-clockwise rotation is available as an option for narrow rooms.)
- Mirror swing arm enclosed with black metal sheathing.
- A horizontal framework holding a vertical shaft, onto which are attached plates for mounting of the lamp or luminaire from above or below.
- Means for adjusting the height of the horizontal arm which holds the vertical shaft and luminaire, using precision linear gearing, motorized and operable from ground level. Height adjustment range capable of allowing lamps and luminaires to be attached by a person standing at ground level.
- Mirror rotation drive motor, which is a high-precision digital stepping motor operating under computer control, manually or automatically.
- Lamp/luminaire rotation drive motor, which is a high precision digital stepping motor operating under computer control, either manually or automatically.
- A silicon photodetector with highly accurate spectral correction, high speed response, high linearity, low drift and low temperature coefficient. Spectral response is $CIE f1' \leq 1.5\%$.
- A housing for the photodetector which incorporates a black screen to block direct light from the test luminaire. An internal rotating aperture is provided which is synchronized with the mirror to block stray light from room surfaces. An automatically closing light-tight shutter is supplied for use during measurement of dark current. Alternatively, a pivoting collimating tube system is available.
- A power supply and operational amplifier electronic package for photodetector signal processing, with multiple amplifier gain (sensitivity) stages.
- Signal Maximizer three channel amplifier system to operate at high speed under computer control, to provide optimization of the photo detector-generated signal. All three amplifiers are read simultaneously.
- Analog-to-digital conversion with three 16-bit converters.
- A Windows-based computer system, supplied as an integral part of the High Speed Moving Mirror Goniophotometer system. The system is configured to provide high speed and large capacity. Specifications change rapidly; please contact Lighting Sciences for information on presently supplied computers.
- A console housing incorporating:
 - Test lamp on/off switch
 - Goniophotometer system on/off switch
 - Goniophotometer electronic interface

- Test lamp/luminaire electrical adjustment control, manual variable transformer (standard) or automatic AC power supply controlled by computer (optional upgrade)
- Emergency off "panic" button
- A digital display indicating volts/amps and watts located on the goniophotometer tower for determination of the electrical characteristics as received at the test lamp or luminaire, relayed to the computer
- Hand-held spark generator for start-up of High Pressure Sodium lamps and pulse-start Metal Halide lamps without the use of an igniter
- Portable hand-held miniature switch box for rotation of the test lamp or luminaire during test set-up and alignment
- Wall-mounted laser aimed at goniophotometer center to assist in setting luminaire height
- Voltage line conditioner for goniophotometer electronics

Software:

All software is Windows XP or Vista based.

- Standard data collection software package, offering:
 - Automatic or manual operation
 - Automated control of mirror rotation
 - Automated control of lamp/luminaire rotation
 - Selectable vertical intensity steps
 - Selectable lamp/luminaire rotation increments
 - Pre-stored standard vertical and horizontal photometric formats
 - Single readings mode with the capability to input the desired mirror and lamp/luminaire angular location, with automatic rotation to selected angles
- Custom data collection software package, offering
 - Operator selectable data collection vertical angles. Specify starting and ending angles, and step increment. Step increment as small as 0.01 degrees.
 - Operator selectable luminaire horizontal angles. Specify starting and ending angles, and step increment. Step increment as low as 0.01 degrees.
 - Output in format compatible with Excel spreadsheet.

Processing programs for data reduction from LSI's Photometric Suite, consisting of software programs TEST-LITE™, NITE-LITE™, FLOOD-LITE™, SPOT-LITE™ and LAMP. All support relative or absolute testing. See separate brochure

- **TEST-LITE™:**
Used for processing all indoor luminaire tests, (fluorescent, incandescent, HID and LED). Software included for intensity plot capabilities.
- **NITE-LITE™:**
Used for processing all area and roadway luminaire tests, (excluding floodlights). Software included for a variety of forms of graphical plotting
- **FLOOD-LITE™:**
Used for processing all floodlight tests. Software included for a variety of forms of graphical plotting. (Type B coordinate output).
- **SPOT-LITE™:**
Used for processing all spotlight, track light and similar equipment tests. Software included for graphical plotting.
- **LAMP™:**
Used for bare lamp calibrations and photometry.

SUMMARY OF TECHNICAL SPECIFICATIONS

Model 6220

- Required ceiling height: Approximately 2.8m (9.1 ft.), plus clearance
- Required room width: Approximately 2.8m (9.1 ft.) for 360° rotation system, plus clearance.
- Required room length: Depends on test distance. Approximately equal to required test distance, most commonly 3 m. (10 ft.).
- Total vertical travel of lamp/luminaire for mounting purposes (motorized): approximately 70cm (2.8 ft.).
- Approximate mirror size: 0.7 x 0.8m. (26 x 30 ins.) for 3 m test distance. Rectangular.

Model 6240

- Required ceiling height: Approximately 4.3m (14.0 ft.), plus clearance
- Required room width: Approximately 4.3m (14 ft.) for 360° rotation system, plus clearance.
- Required room length: Depends on test distance. Approximately equal to required test distance, most commonly 8 m. (26 ft.).
- Total vertical travel of lamp/luminaire for mounting purposes (motorized): approximately 1.5m (5.0 ft.).
- Approximate mirror size: 1.1 x 1.4m. (43 x 55 ins.) for 8 m test distance. Octagonal

Model 6440

- Required ceiling height: Approximately 5.4m (17.8 ft.), plus clearance
- Required room width: Approximately 5.4m (17.8 ft.) for 360° rotation system, plus clearance.
- Required room length: Depends on test distance. Approximately equal to required test distance, most commonly 8 m. (26 ft.).
- Total vertical travel of lamp/luminaire for mounting purposes (motorized): approximately 1.8m (5.9 ft.).
- Approximate mirror size: 1.3 x 1.7m. (52 x 63 ins.) for 8 m test distance. Octagonal

All Models

- Mirror type: 6mm float glass, protected silver backing. Tilt angle set for desired test distance.
- Rotational speed of mirror: up to 6 revs. per minute.
- Power delivery to test lamp/luminaire: Cable with attachment terminals. (No slip rings required.)
- Maximum luminaire weight: 60 kg (130 pounds)
- Counterweight: Balances mirror and swing arm.
- Digital stepping motor for mirror drive, resolution = 0.01°. Continuous rotation capability, or move to specific angles.
- Digital stepping motor for test lamp/luminaire drive, resolution = 0.01°. 360° rotation capability with automatic return to starting location at end of test. Manually can move to specific angles by computer command.
- Digital display of electrical power:
 - Yokogawa WT110 or equivalent, with computer interface
 - Frequency range 10Hz to 50kHz
 - Range:
 - Voltage 0-600v
 - Current 0-20 amps
 - Power 0-12,000 watts

- Detailed accuracy specifications available. Additional meter is optionally available for use with calibration standard lamps.
- Electronic Protection: Separation of power electrical system and electronic system for prevention of electrical cross-talk.
- Photodetector Amplifier System: Located next to the photodetector to maximize signal-to-noise ratio.
 - Three simultaneously operating amplifiers with multiple gain (sensitivity) stages, digitally selected via LSI Signal Maximizer circuit and computer software for maximum dynamic range.
 - Amplifier linearity $\pm 1\%$ over each amplifier gain stage from maximum reading to less than 1% of maximum
 - 16 bit resolution analog-to-digital converter for each of three amplifier channels.
- Silicon photodetector, corrected to CIE $V(\lambda)$ spectral response curve, $f_1' \leq 1.5\%$. Mounted in housing with black screens to remove stray light and any direct light from the test item.
- Rotating aperture in photo detector housing, synchronized with mirror rotation, to further absorb room stray light. A pivoting collimating tube system is alternatively available – please request details.
- Input power: 120 VAC $\pm 10\%$, 60 Hertz. Other voltages or 50 Hz available. Power supply details upon request.
- Test time: Data collection time for typical indoor luminaire: approximately 3 minutes.
- Test time: Data collection time for typical outdoor luminaire: approximately 11 minutes.
- Measurement range: At 8m test distance, approximately 10,000,000 candelas to < 1 candela

DETAILED TECHNICAL SPECIFICATIONS

Available upon request. Please specify model 6220, 6240 or 6440

OPTIONAL EQUIPMENT

Available optional equipment consists of individual accessories or complete systems providing enhanced capabilities.

SLI-120: Intensity Standard Lamps

Lighting Sciences maintains equipment directly calibrated by the US National Institute of Standards and Technology. Standard lamps provided by LSI are calibrated in one step to this NIST-calibrated standard.

Intensity standard lamps are available also with total luminous flux calibration. LSI goniophotometers can be calibrated using either intensity or total flux, software selectable.

Pin base matches LSI Kelvin Socket KS-10

KS-10: Kelvin Socket, (four terminal), for intensity standard lamps.

PSDC-120: Power supply for intensity standard lamps, 0-150 VDC.

DMM-10: High precision digital multimeter for standard lamp monitoring. Used in conjunction with PSDC-10 power supply.

PSAC-1250: Computer controlled AC power supply for automatic test lamp voltage or power control. Includes computer interfacing, automatic monitoring and adjustment software, and software controlled test lamp warm-up control.

BR-V-MED: Mounting bracket for medium screw base lamp, base up

- BR-V-MOG: Mounting bracket for mogul screw base lamp, base up
- BR-H: Mounting bracket for screw base lamp, horizontal. Uses medium or mogul socket from vertical bracket.
- B-SL4: Holding bracket for 1.2m (4 ft.) fluorescent strip lights
- B-FL24: Holding bracket for fluorescent luminaires, 0.6 x 1.2m (2 x 4 ft.)
- B-FLB24: Holding bracket for bare fluorescent lamps for use during calibration. Use with B-FL. Up to 4 lamps T5, T8 and T12. Includes black divider screens.
- B-HID: Multi-purpose machined mounting plate for High Intensity Discharge luminaires.

ADDITIONAL TEST SYSTEMS

Photometry of Flashing Sources

Please request details of optional equipment for automated flash goniophotometry.

Near-field System

Optional equipment is available to provide near-field measurements in addition to the standard far-field system. Please request details.

Spectral Data

With the optional spectrophotometer system, spectral goniophotometry can be performed. Please request details.

LSI High Speed Moving Mirror Goniophotometer vs. Other Available Mirror Goniophotometers

Lighting Sciences Inc.'s High Speed Moving Mirror Goniophotometer offers features that either far surpass or are completely unavailable in competitive systems. This section compares the features of the LSI High Speed Moving Mirror Goniophotometer system versus standard goniophotometer features.

High Speed Moving Mirror Goniophotometer vs. Standard Photometers		
Feature	High Speed Moving Mirror Goniophotometer	Standard Photometers
Motor Drives (Mirror & Luminaire Rotation)	Precision digital stepping motors ensure exact computerized positioning.	DC gear motors coupled to an angle encoder can cause inaccuracies due to misalignment, wear, and deterioration with time.
Angle Lock-In in Single Readings Mode	Exact horizontal and vertical angles are entered via the computer; goniophotometer is positioned by the digital stepping motors.	DC driven motors are difficult to position at an exact angle given variable speed control and inertia of these systems.
Angular Resolution of Motors	+/- 0.01 degrees – important factor where intensity changes rapidly with angle.	+/- 0.1 degrees or more – Can lead to significant errors in narrow beam, high intensity situations.
Photo Detector Electronics	"Signal Maximizer" circuitry automatically sets the amplifier gain to optimum and	Amplifier gain setting for the photodetector is adjusted manually by the test operator

High Speed Moving Mirror Goniophotometer vs. Standard Photometers

Feature	High Speed Moving Mirror Goniophotometer	Standard Photometers
	adjusts it if required during the test run. 16 bit A-to-D converters for very wide dynamic range.	and remains the same throughout the test. Large errors are possible. May use 8 bit A-to-D converter giving significantly limited dynamic range.
Intensity Accuracy	"Signal Maximizer" system ensures optimum accuracy at all intensity levels using three amplifiers read simultaneously.	Significant errors possible when test item has wide range of intensities, particularly for low candela levels.
Very High Speed Mirror	Mirror speed of up to 6 rpm can be used. Data collection time for an indoor luminaire reduced to about 3 minutes.	Slow mirror rotation may be needed to prevent mechanical instability. Can greatly increase data collection time.
Ultra-fast Electronics	Data gathered at a rate of 6,000 readings per second or greater. Allows integration over 50 or 60 Hertz waveform. Captures narrowest intensity peaks.	Slow data collection of only a few readings per line cycle may introduce errors due to 50 or 60 Hertz stroboscopic effect. Narrow high intensity peaks may be improperly measured.
Dark Current Compensation	The amplifier's signal when no light is on the photodetector is automatically read and stored for each gain setting. Values are automatically subtracted during testing, eliminating this error.	No automated way to compensate for the amplifier's signal during test sequence. Since each amplifier gain setting has a different "dark current" value, errors up to 10% are possible.
Computer System	Equipped with Windows XP or Vista system with high-quality peripheral equipment. Brand name hardware: parts and service for components available worldwide.	May have limited features, speed and peripherals. Brands vary widely potentially leading to parts and service problems.
Luminaire Mounting System	Mounting system is electrically raised or lowered to allow the operator to attach the luminaire while standing at ground level.	Standard luminaire mounting systems require the use of a step ladder or other inconvenient means, leading to potential safety liabilities.
Mechanical Design	Mirror rotates around a fixed axis with luminaire attached to a high strength steel shaft and frame. Stable platform results in high-speed test without errors caused by mechanical design.	May use thin mounting frameworks and may require the luminaire height to change during test if luminaire rotates around a central mirror. Structure and continuous movement of luminaire introduce possibility for errors due to air currents & temperature effects.
Direct & Indirect Luminaires	Uplight and downlight testing is achieved through the use of an upper and lower mounting plate which does not require inverting the luminaire.	Most systems use a pivoting alignment plate to mount direct or indirect luminaires, leading to potential misalignment and extra test setup time.
Appearance & Packaging	A clean, sleek black metal sheathing covers all framework. Miniaturized control console. Highly professional appearance.	Little attention may be given to appearance, and old-fashioned control panels may be very large and use valuable room space.

High Speed Moving Mirror Goniophotometer vs. Standard Photometers

Feature	High Speed Moving Mirror Goniophotometer	Standard Photometers
Photo Detector	Extremely fast response time, excellent linearity and low temperature coefficient. No need for individual cooling options that may be unreliable. Excellent $V(\lambda)$ spectral correction, $f_1' \leq 1.5\%$	Systems may need an individually cooled photodetector to control signal to noise. $V(\lambda)$ correction varies or may not even be specified.
Software	Data collection, reduction and report generation software is unparalleled in its capabilities. No other manufacturer can offer a range of software comparable to that of Lighting Sciences' Photometric Suite and custom software packages.	Standard photometric software may have limited features. Systems may produce proprietary format data files which are not usable by other programs such as lighting design and analysis software.
Room Size	Compact. Minimum building space required. Ceiling height of only 4.3 m. (14 ft.) handles 1.2 x 0.6 m. (2 x 4 ft.) luminaires.	May need much larger room. Some designs even need a floor pit (which may be a safety concern).

Lighting Sciences Inc.

7826 East Evans Road
Scottsdale, Arizona 85260 U.S.A.
Phone: 480.991.9260
Fax: 480.991.0375

www.lightingsciences.com



Excellence in Photometrics

Brand and product names are trademarks or registered trademarks of their respective holders. Copyright © Lighting Sciences 1996-2009. All Rights Reserved. Information contained in this document is subject to change without notice and does not represent a commitment on the part of the vendor. Lighting Sciences Inc. does not assume any liability arising out of the application or use of any product described herein.

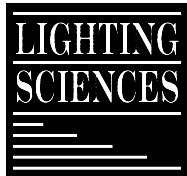

High Speed Moving Mirror Goniophotometer Models # 6220, 6240 and 6440

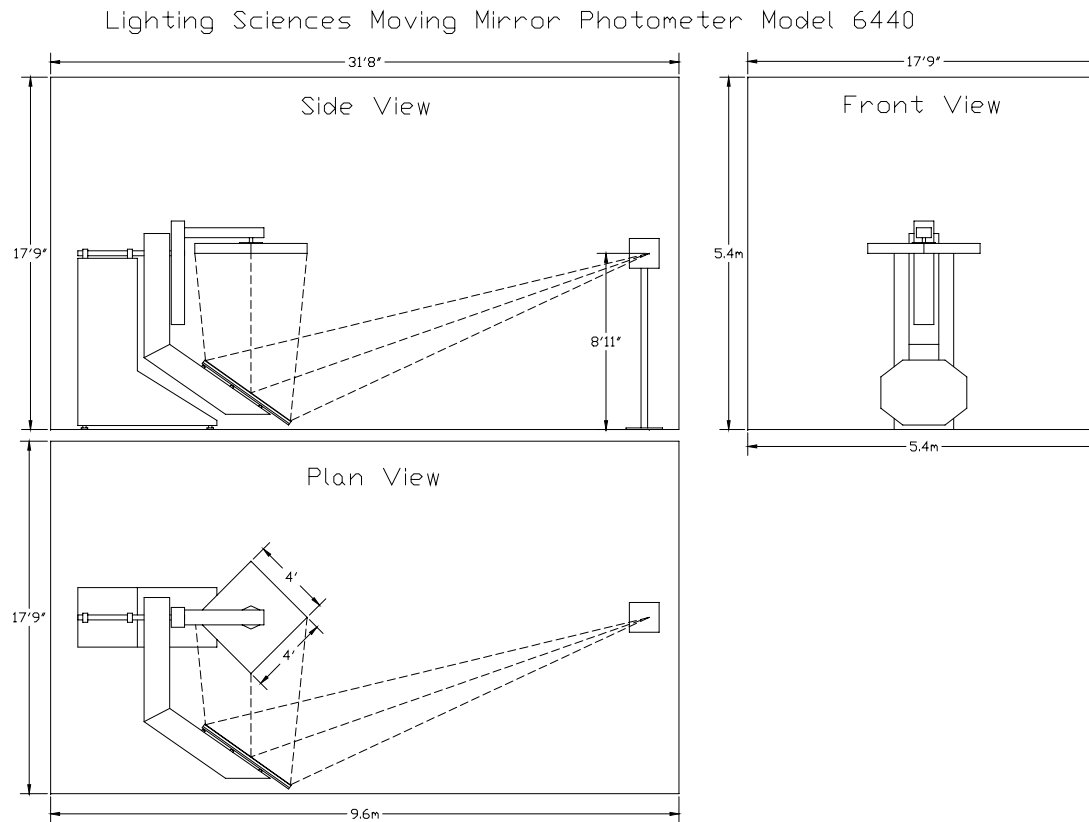

Side view of typical laboratory layout for the High Speed Moving Mirror Goniophotometer.
Exact dimensions may vary.
Contact Lighting Sciences Inc. for assistance in planning the layout of specific laboratory requirements.

Lighting Sciences Moving Mirror Photometer Model 6240

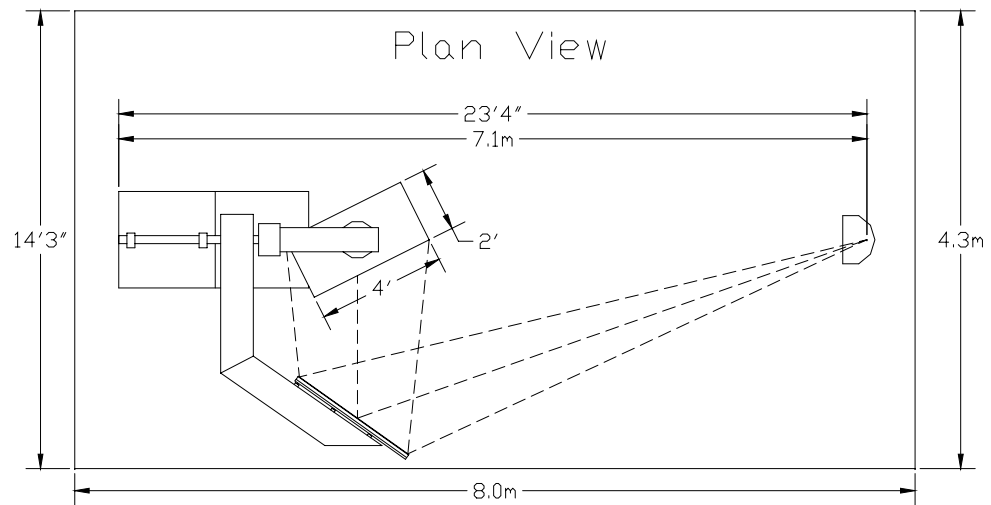
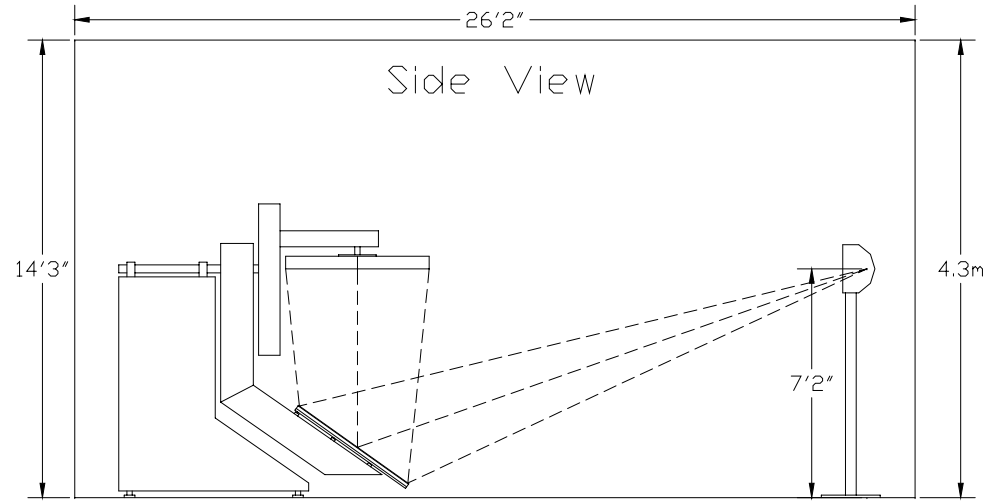

Lighting Sciences Moving Mirror Photometer Model 6220

